

Oil Level Regulator Installation Instructions

Parts List

Part	Description	Part Number
A	Front Window Kit – One Piece Isoplast with Gasket and Screw Set	3945565 S
B	Valve Assembly With Float	3946910 S
C	Valve Gasket	3945567 S
D	Sediment Bowl Screen and Gasket Combo	3967685 S
E	Sediment Bowl Inlet (supplied as part of Sediment Bowl Service Kit)	3946906 S
	Metal Sediment Bowl Service Kit	3965311 S
F	Assembly Screw Set	3946911 S
G	1/2" NPT Plug	3946905 S
H	Switch Assembly	3945562 S
I	Body Casting	N/A
J	Unvented 1/4" NPT Plug	3946907 S
K	Mounting Plate Gasket	3945563 S

Part	Description	Part Number
L	Slotted Mounting Plate	3946908 S
M	Aluminum "Y" Mounting Bracket	3946909 S
	Slotted Aluminum "Y" Mounting Bracket (not shown)	3968805 S
N	Hose Clamps (4 Required)	N/A
O	1/2" NPT Barbed Nipples (4 Required)	3945560 S
P	Neoprene Hose	N/A
Q	Front Ring Screw Set	3945569 S
R	Front Ring	3948644 S
S	Front Window – Glass	3945207 S
T	Window Gasket (2 required – each side of window)	3945568 S
U	Complete Gasket Set (Not shown - Includes parts A1, C, D, K, and L)	3945217 S

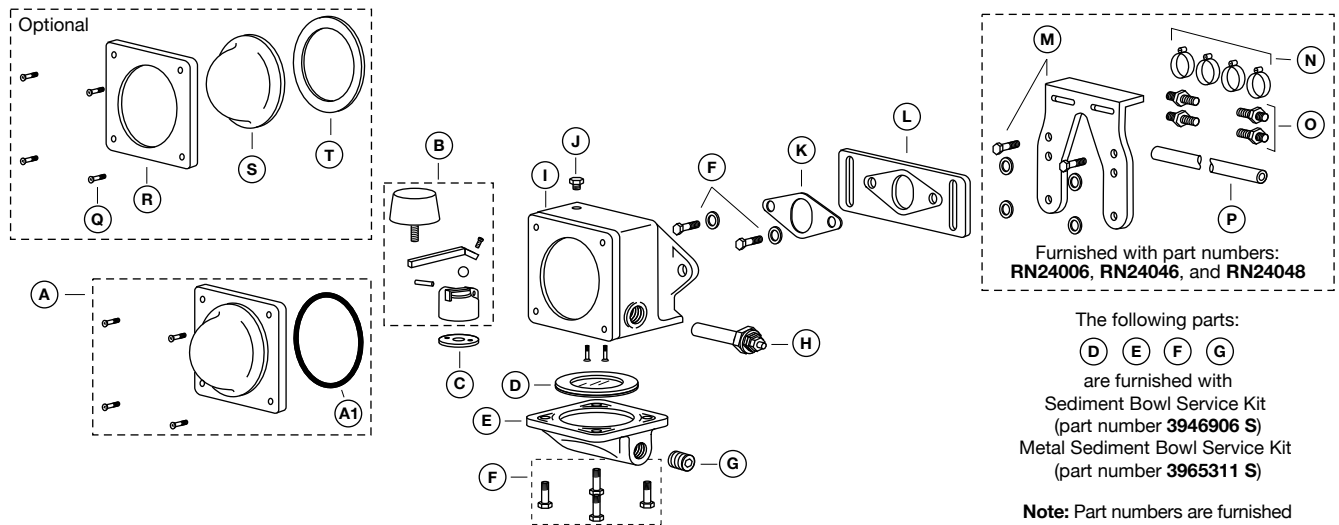

⚠ CAUTION: These instructions are intended for use by professional mechanics who are trained in the proper use of power and hand tools, using appropriate safety precautions (including eye protection).

Introduction

The Fleetguard REN™ Oil Level Regulator can be mounted to an accessory bracket and bolted to an engine, crankcase or can be mounted directly on engines and compressors equipped with a sight glass.

From a separate supply tank at or near the engine, the regulator delivers only the amount of oil required to maintain a constant oil level in the engine crankcase. The float valve is insensitive to vibration.

The regulator should be mounted on or adjacent to engine crankcases with the centerline of the window in the regulator adjusted to the same height as the level of oil in the crankcase. If space limitations prohibit mounting on the crankcase, the regulator can be mounted in a level position as close as possible on an adjacent member.

The regulator mounting bracket can be inverted and installed on the engine skid, if preferred.

Note: Most multi-cylinder engines have an operating crankcase pressure approximately atmospheric. Some engines tend to develop a positive pressure while others develop a negative pressure in the crankcase. A pressure equalizing vent line between the Oil Regulator and these engines with positive or negative crankcase pressure is necessary for proper operation. We recommend the same approach for other applications where the engine venting might become restricted or was insufficient. RAB product is recommended for engines with minimum four cylinders.

Installing the Oil Level Regulator

1. Install a clear tube, with enough length to reach above the running level of the oil, to the auxiliary drain plug or a tee in the existing drain plug.
2. Start the engine and mark the tube with the running level of the engine oil.
3. Shut the engine down and drain the oil pan so the oil on the dipstick is at the "Add" line.
4. Mount the "Y" bracket so the marks on the tube are in the middle of the regulator mounting slots.
5. Mount the regulator so the "Add" line is in the middle of the yellow float in the regulator window.

6. Remove the brass 1/4" (6.35 mm) NPT pipe plug on the top of the regulator.
7. A vent line **MUST** be fitted. Connect a vent line, 3/8" (9.53 mm) I.D. minimum, from the port on the top of the regulator to a port on the engine that is above the oil level – for best performance vent line should be 3/8" (9.53 mm) I.D. minimum. If no port is available below the pistons you can connect to the valve covers (see Figure 1).
8. Connect the engine supply line, 1/2" (12.7 mm) I.D. minimum, from the outlet of the regulator to the auxiliary drain plug or a tee in the existing drain plug (see Figure 1).
9. Connect the regulator supply line, 1/2" (12.7 mm) I.D. minimum, from the reserve oil tank to the regulator inlet (see Figure 1).
10. Start the engine and allow the oil level to stabilize.
11. Check the oil level on the dipstick, if the oil level is low adjust the regulator higher on the bracket to allow more oil into the crankcase. If the oil level is above the full line on the regulator, drain the excess oil out of the crankcase and move the regulator down on the bracket.
12. Repeat steps 9 and 10 until desired running oil level is achieved.

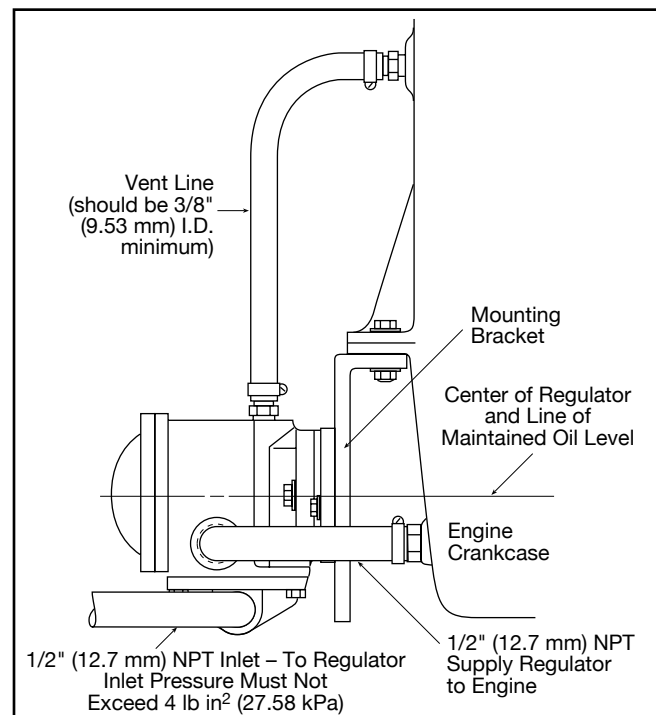

Figure 1 – Installing the Regulator

Installing the Oil Level Regulator as a Visual Indicator of Crankcase Oil Level Only

To use the Oil Level Regulator to monitor crankcase oil levels, follow the instructions for standard installation (beginning on page 2). However, instead of installing a line from the oil supply tank (Step 9), install a pipe plug (not supplied).

For convenience, a line can be drawn or painted across the center of the clear lens (preferably not in black) so that there is an indication of the oil level. This line would indicate the running level; anything above or below the line would indicate an over or under situation.

If an oil reservoir is added at a later date, simply connect it to the inlet port on the Oil Level Regulator.

Typical Installation

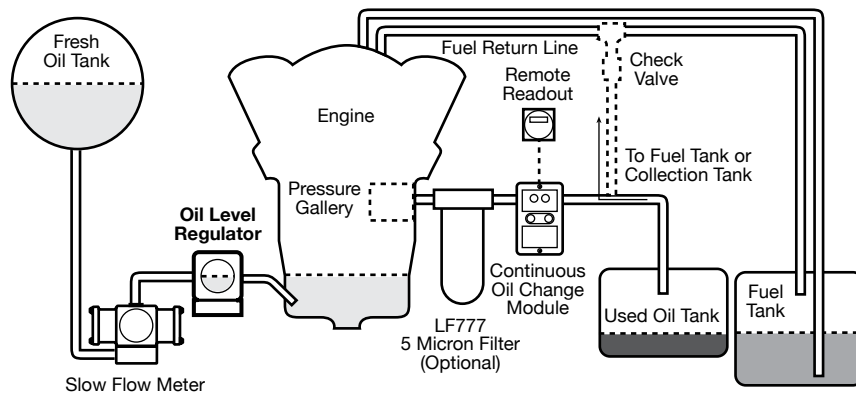

Ordering Information

Part Number	Description
RN24006	Oil Level Regulator with mounting bracket, hose, and fittings
RN24007	Oil Level Regulator without mounting bracket, hose, and fittings
RN24046	Oil Level Regulator with metal bowl, mounting bracket, hose, and fittings
RN24048	Oil Level Regulator with 1/2" slotted mounting bracket, hose, and fittings

Specifications

Specification	REN™ Oil Level Regulator
Height Overall (Without Bracket)	5.00" (136.53 mm)
Depth Overall	7.13" (180.98 mm)
Width, Max. (Without Bracket)	4.38" (111.13 mm)
Mount Bracket Centers	5.26" (133.60 mm)
Weight (Dry)	9 lbs (4.08 kg)
Fuel Oil Connections (Inlet)	1.2" NPT
Fuel Oil Connection (Outlet)	1.2" NPT
Min Vent Hose (I.D.)	3/8" (9.53 mm)
Max Inlet Pressure	4 in ² (27.58 kPa)

Dimensions

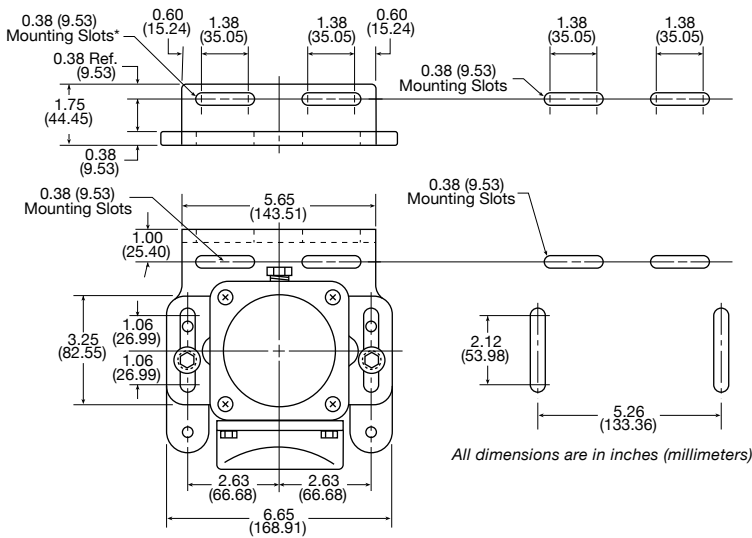

* 1/2" Slotted Bracket Available, part no. **3968805 S**

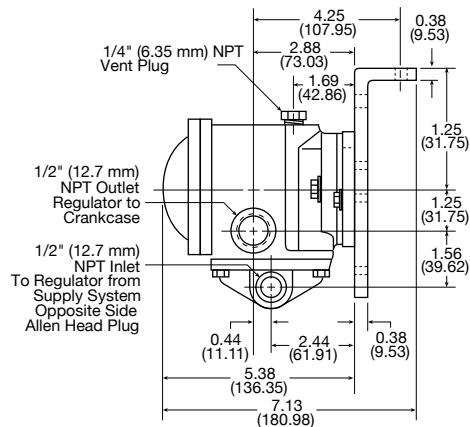

Filtration

For more information, visit
cumminsfiltration.com

LT32567 – Rev. 9
F1301

©2009 Cummins Filtration Inc.
Printed in the U.S.A.