

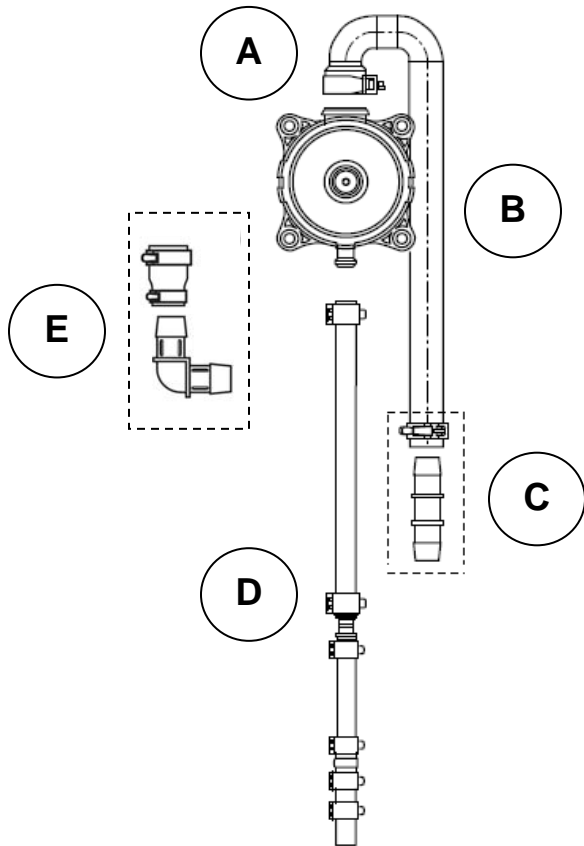

# Fleetguard® OCV Crankcase Ventilation Kit Installation Instructions For Cummins Natural Gas Engines

## Installation Instructions for

- G/GTA5.9 Engine Model    KIT CV 50123
- G/GTA8.3 Engine Model    KIT CV 50125
- G/GTA855 Engine Model    KIT CV 50125
- KTA19GC Engine Model    KIT CV 50127
- KTA38GC Engine Model    KIT CV 50127



### Parts List

Part	Description
A	Breather Assembly
B	Vent Hose
C	Vent Hose Connector and Clamps
D	Drain Hose Assembly
E	Inlet Connector Kit
F	Bracket (optional)

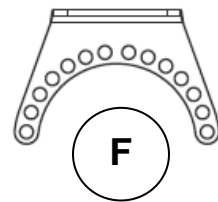

**⚠ CAUTION:** These instructions are intended to be used by professional mechanics that are trained in the proper use of power and hand tools, using appropriate safety precautions (including eye protection).

## Crankcase Ventilation Kit Installation

### Pre-Installation Notes

The Fleetguard® OCV Kit can be installed on many different engine platforms. Since engine design varies broadly, connection and fitting sizes will also vary by engine. Each pack is identified with a label to reference its use in an appropriate installation step.

Please remember these points:

- Read all of the instructions thoroughly before attempting the installation.
- We strongly suggest not drilling holes into the engine block or oil pan.
- All materials, hoses, fittings, etc., must be oil resistant with a temperature rating -40 up to +212°F (-40 up to +100°C).
- While the engine is running, the impactor and hoses should not be allowed to freeze.

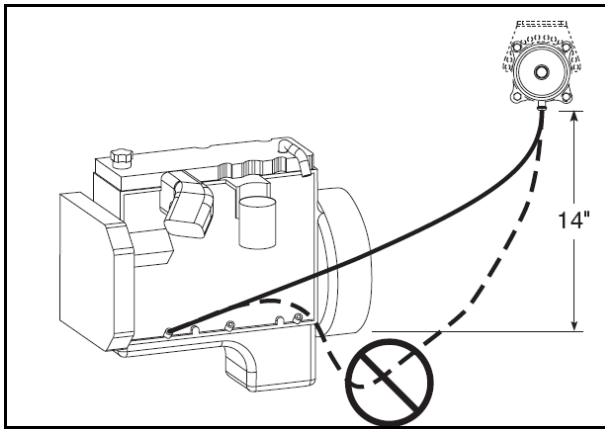

Steps 1 & 2

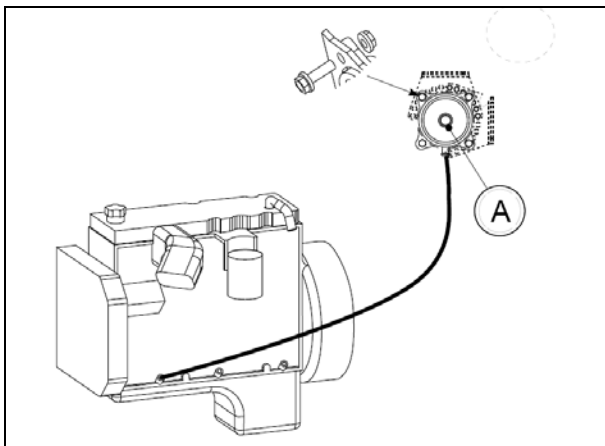

Step 3

### Locating and Mounting the Breather Assembly

**Step 1** - Check both sides of the cylinder block to determine the most suitable oil return option. Select a threaded boss or another entry option that will allow the drain hose, when installed, to run directly from the breather assembly to the crankcase. **The drain hose must be free of any loops, kinks or abrupt bends to ensure proper oil drainage.**

**Step 2** - Find a mounting location for the breather assembly and bracket at least 14 inches (350mm) above oil level in crankcase\* and a minimum 4 inches (102mm) from both the exhaust manifold and exhaust piping. The “cold side” of the engine is preferred. The breather assembly must be mounted vertically (as shown) for proper operation.

**Step 3** - Install the breather assembly to the mounting location, ensuring the breather assembly is positioned vertically and the oil drain outlet is directed downward. 9mm Grade 5 bolts are suggested.

\* see also Caution after Step 8

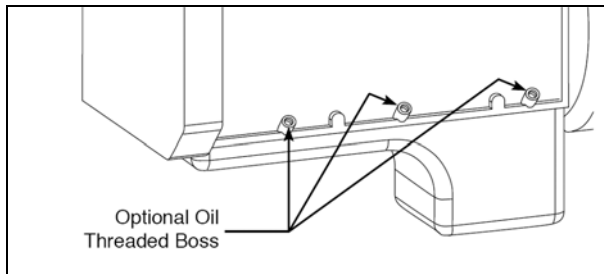

Step 4

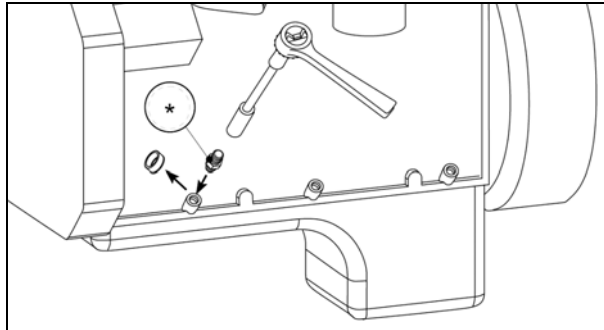

Step 5 &amp; 6

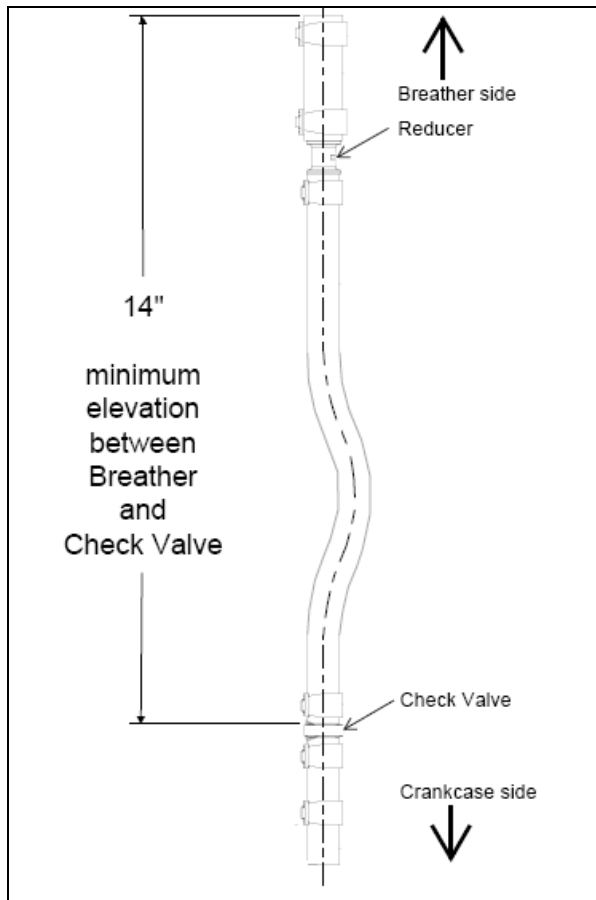

Drain Hose Assembly

## Installing the Insert Fitting

**Step 4** - Locate the selected threaded boss at the bottom of the cylinder block (above the pan rail) for installation of the cylinder block insert fitting. Check the boss opening ID to determine the fitting to be used.

Check with the engine manufacturer on the proper fitting to access the crankcase. Once the proper crankcase fitting has been selected, proceed with step 5.

**Special Note:** This Kit does not contain any fittings that connect directly to the engine. Be sure the fitting will connect to 3/8" ID Hose – additional adapters might be required.

**Step 5** - Remove the plug from the boss carefully to ensure that no contamination enters the crankcase.

**Step 6** - Install the new insert fitting by screwing it into the threaded boss. Tighten the fitting until it is properly seated against the boss. **Do not overtighten.**

## Installing the Drain Hose

The drain hose assembly is three sections of hose with plastic connections. The smaller ID hose (0,375 inch; 13mm) connects to the barbed insert coupler. The larger hose (0,5 inch; 13mm) connects to the breather assembly.

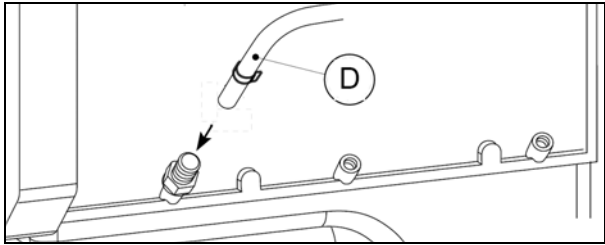

Step 7

**Step 7** – Connect the drain hose assembly to the crankcase fitting. Position the hose clamp to insure a good seal.

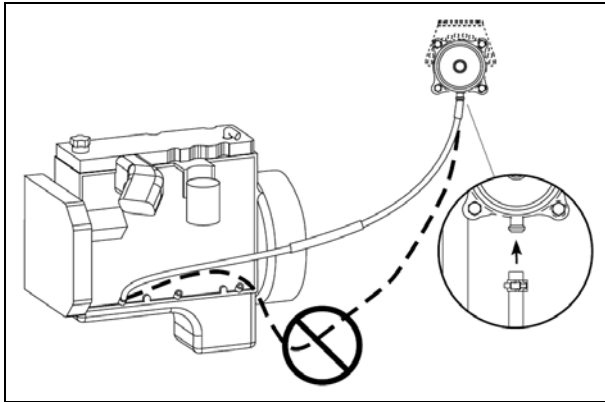

Step 8 & 9

**Step 8** – Route the drain hose to the breather assembly to determine the proper length.

**⚠ CAUTION:** The drain hose must be free of any loops, kinks or abrupt bends to ensure proper oil drainage. The Check Valve must be a minimum of 14” below the Impactor.

**Step 9** – If the hose is too long, trim the excess from the larger ID section of the hose. Attach to the breather, and secure with the clamp. **Re-inspect the hose and routing to verify it is free of any loops, kinks or abrupt bends.**

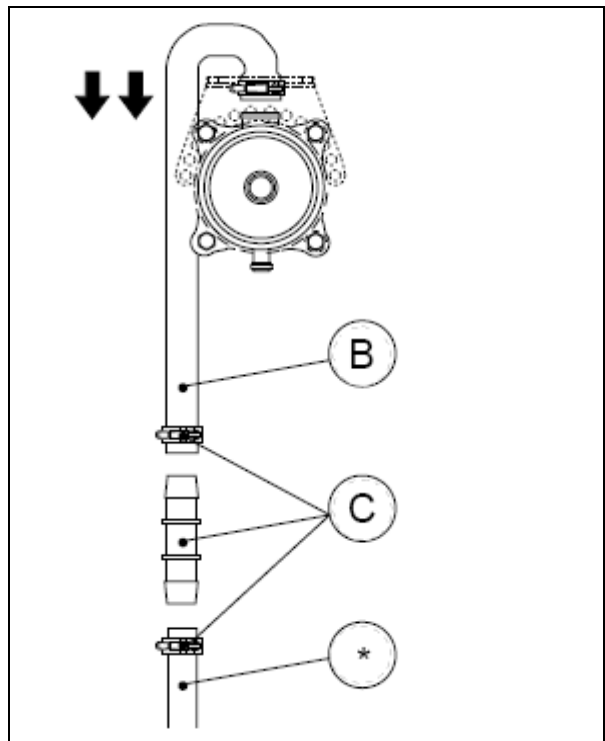

Step 10 & 11

### Installing the Vent Hose and Extension Vent Hose to the Breather Assembly

**Step 10** – Using the clamps and plastic connector in the “D” pack, assemble the vent hose. First slide the hose clamps over the hoses to be joined. Then join the two vent hoses together using the plastic connector. Reposition the clamps to secure both hoses to the connector.

**Step 11** – Install the curved end of the vent hose assembly to the breather by first slipping the remaining clamp in the “D” pack over the end of the hose. Push the hose over the breather outlet. Secure with the clamp. Ensure the entire vent hose is directed downward and free of any loops, kinks, or abrupt bends.

Stabilize the vent hose assembly by attaching tie wraps from the hose to a secure point in the engine compartment.

\* User supplied hose to be SAE 20R3 Class B inside & Class C outside or better

**⚠ CAUTION:** Do not collapse or kink the hose when securing the tie wraps. Ensure the vent extension is pointed downward.

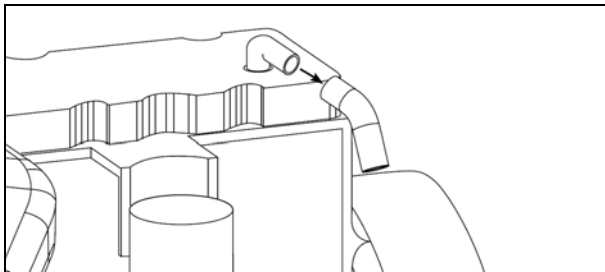

Step 12

### Installing the Breather Inlet Hose Assembly

Installing the breather inlet hose assembly first requires determining needs for the engine application.

For engines with a dual breather vent design, an additional installation kit will be required. The installation kit is part No.: 394316000S (99691K).

**Step 12** – Remove the existing breather hose from the engine and determine the OD of the metal breather vent tube. Select the appropriate inlet hose connection based on the metal vent tube OD dimension on first end of the hose, and plastic 90 degree connector OD on second end of the hose.

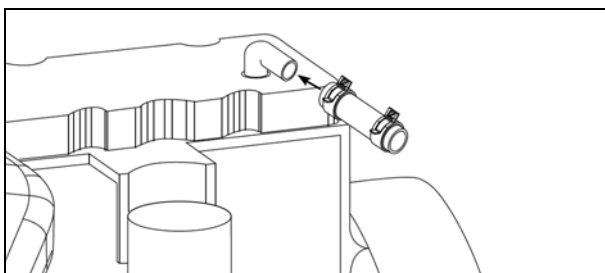

Step 13

**Step 13** – Install the correct hose to the engine vent tube and secure with the clamp.

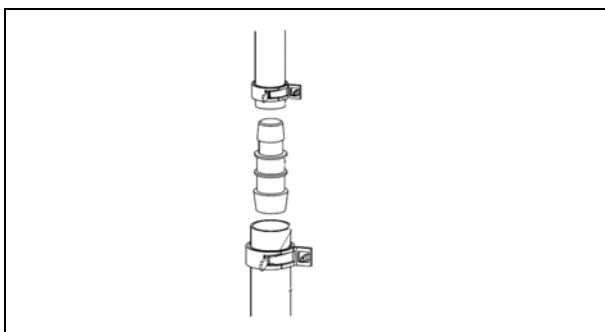

Step 14

**Step 14** – If necessary connect the inlet hose assembly using additional reduction connectors. First slide the hose clamps over the hoses to be joined and then join the hoses together using the connector. Reposition the clamps to secure both hoses to the connector.

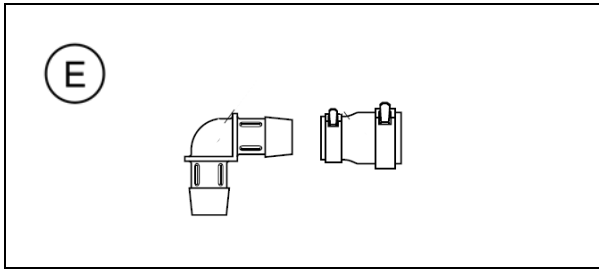

Step 15 & 16

**Step 15** – Route the new inlet hose assembly to the breather assembly. Depending on the hose routing, determine the best position for the 90 degree connector. The 90 degree connector can be used depending on the location of the engine vent and the hose routing.

**Step 16** – Preassemble the hose adapter to the connector, and secure with clamps.

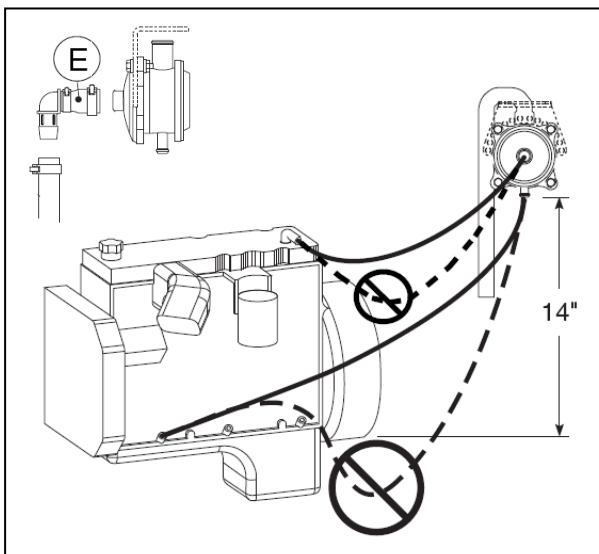

Step 17

**Step 17** – Install the adapter to the breather and secure with the clamp. Route the inlet hose to the plastic breather connector. Trim the hose to the proper length. Attach the hose to the breather connector and secure with the clamp.

**⚠ CAUTION:** Ensure the hose routing is a minimum of 4 inches (100mm) from both the exhaust manifold and exhaust piping. Avoid trimming too short to prevent hose kink after installation.

---

**Applications for other natural gas engines according to Rated Power**

<b>Application</b>	<b>KIT No.</b>
<b>60-90 HP Applications</b>	<b>KIT CV 50123</b>
<b>91-120 HP Applications</b>	<b>KIT CV 50124</b>
<b>121-160 HP Applications</b>	<b>KIT CV 50125</b>
<b>161-220 HP Applications</b>	<b>KIT CV 50126</b>
<b>221-300 HP Applications</b>	<b>KIT CV 50127</b>

---

**⚠ CAUTION:** Natural Gas Engines require oil analysis and the monitoring of the crankcase oil condition. The addition of a crankcase ventilation system that returns condensed oil to the crankcase may affect the rate of change for some characteristics. Be sure to closely monitor the water, TBN and pH levels in engine oil. Adjust the preventive maintenance intervals as needed to achieve a comfortable level of oil quality.

---

**Breather Assembly – Dimensions, inches (mm)**

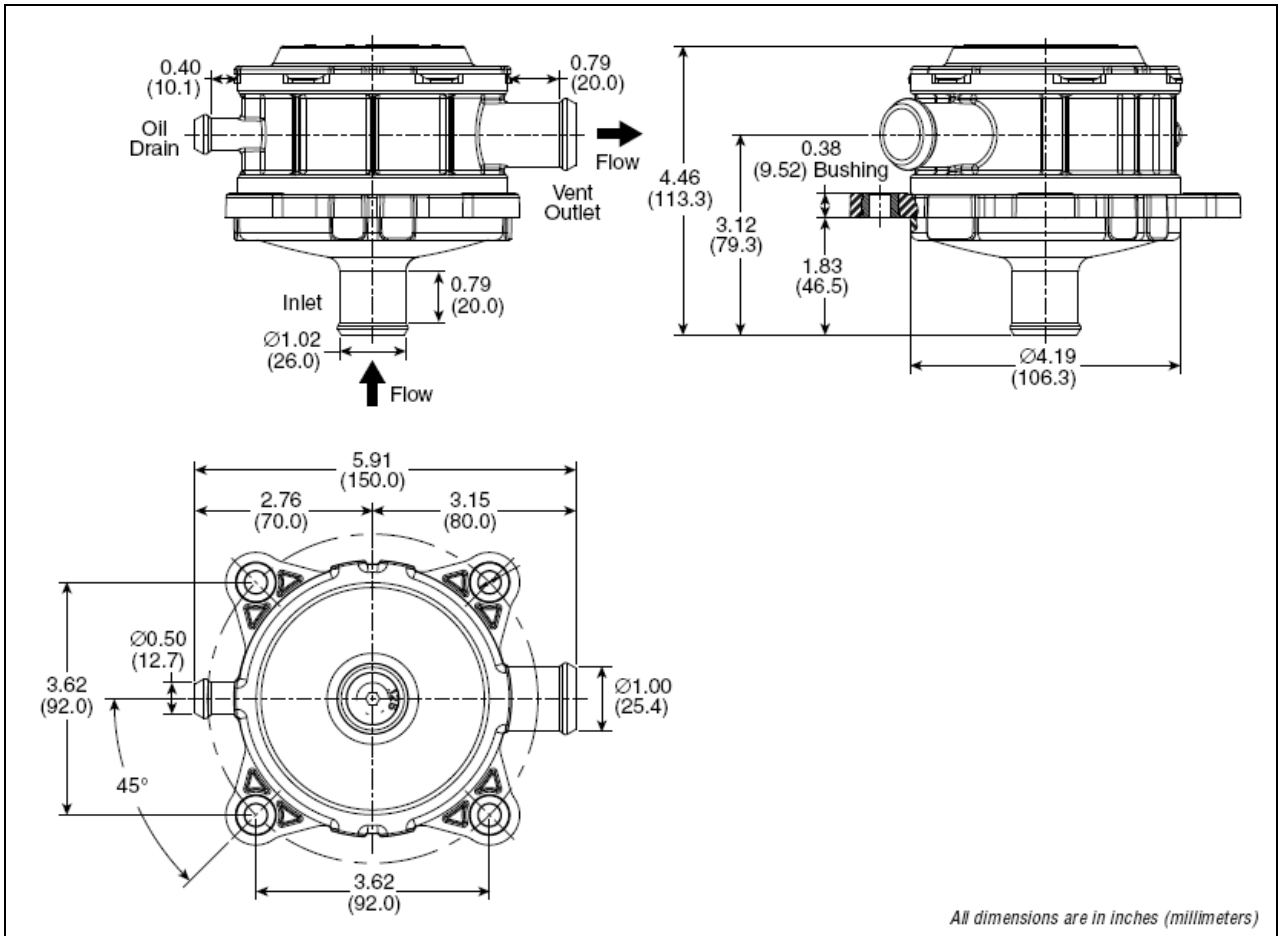

### Optional Mounting Bracket – Dimensions, inches [mm]

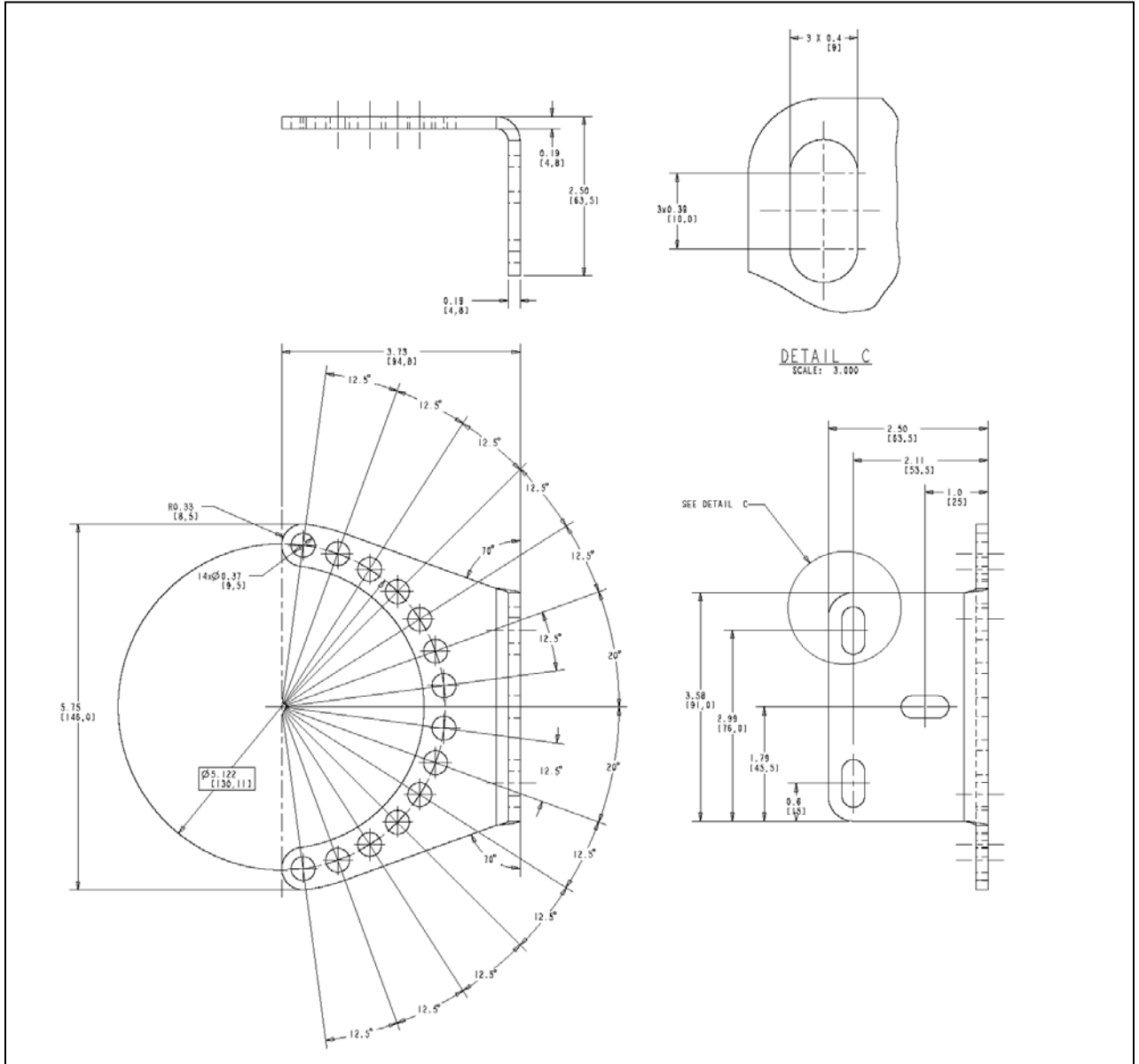

For more information, visit [cumminsfiltration.com](http://cumminsfiltration.com)

LT36134

©2009 Cummins Filtration